

WATSON
MARLOW
PUMPS

S E R I E S

800

High-flow
Hygienic Pumps

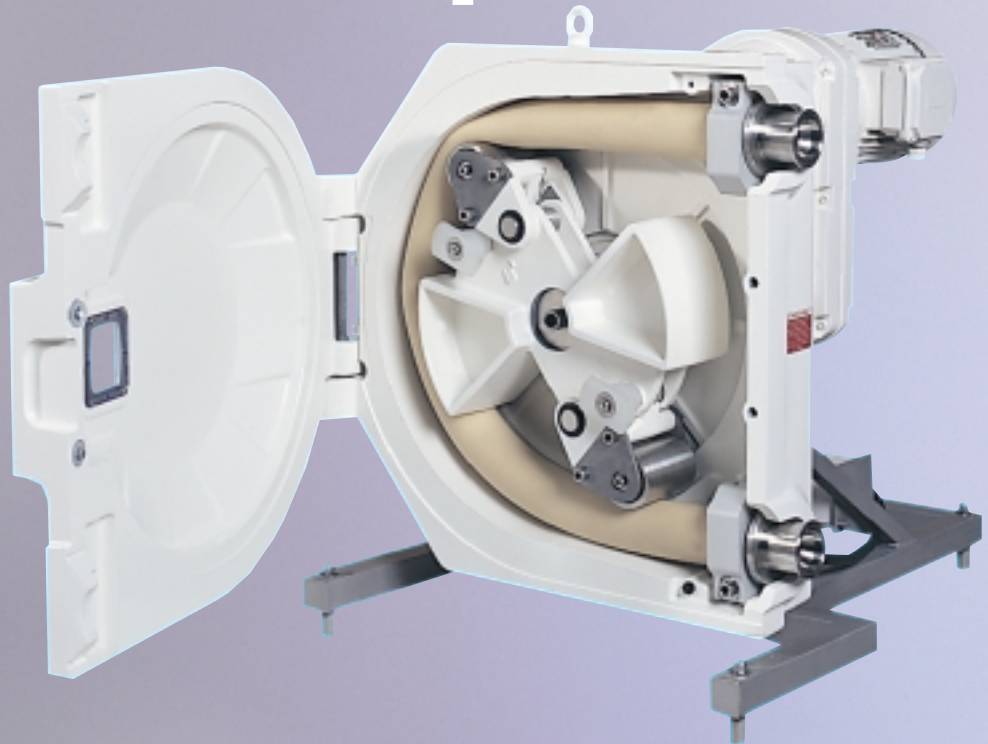



Watson-Marlow leads the world in solving fluid handling problems with peristaltic pumping technology. The company is accredited for design and manufacture to ISO9001, and provides its customers with nothing less than the best products, service and knowledge. Watson-Marlow conducts its business ethically, and stands by its word, its recommendations and its products.

Put Watson-Marlow to work on your pumping problems

■ Watson-Marlow peristaltic pumps are problem solving pumps, best applied where other pump types fail or frustrate. Watson-Marlow works only through trained engineers, and, wherever you are, they will work with you, using the experience of meeting and solving literally thousands of pumping problems.

■ As the largest peristaltic pump manufacturer, with a range of pumps and tubing for flow rates from microlitres per hour to thousands of litres per hour, we stand every chance of helping you, but if we cannot we will tell you.

■ If we can help, we will do whatever is necessary to prove to you that it will do the job. Any product we recommend, we will stand by completely, and if it fails to meet the agreed need, then that will be our problem and not yours.



The benefits of peristaltic pumping

Compared to lobe pumps, diaphragm pumps, gear pumps and piston pumps, and every other type of pump, these are the advantages of Watson-Marlow pumps:

- 1 No contamination of the fluid.
- 2 No contamination of the pump.
- 3 Ideal for shear-sensitive and aggressive fluids.
- 4 Self-priming, dry-running.
- 5 No valves, seals or glands.
- 6 Automatic check valve action prevents backflow.



PERISTALTIC PUMPS ARE IDEAL FOR

- Abrasive and aggressive fluids
- Beverage dispensing
- Cell culture
- Fermentation
- Filtration and separation
- Food processing
- Industrial chemicals
- Inks and pigments
- Pharmaceuticals
- Photographic solutions
- Water treatment

WATSON MARLOW

Purchasers in the EU please note

825 and 840 pumpheads are specially designed for connection by the user to gearboxes of the users choice and they do not carry the  mark. These pumpheads are supplied with "Declarations of Incorporation" as required by the EU Machinery Directive.

The B/RA and the RA bare shaft pumps carry the  mark, but the complete motorised pump assembly must also carry the assembler's  mark in addition to the Watson-Marlow  mark.

Customers in EU member States must note that self assembly of machines carries with it the responsibility to ensure that the final working assembly complies with all the relevant EU safety directives and the assembler's  mark is affixed on completion.

Standards

 Conforms to all relevant Directives

IEC 335-1 is the International Electrotechnical Commission standard dealing with the "Safety of household and similar appliances, general requirements". Equivalents are BS3456: Part 101 and DIN VDE 0700: Part 1).

EN60529 is the European Norm standard dealing with the "Classification of degrees of protection provided by enclosures for rotating machines. Equivalents are BS 4999: Part 105, IEN 60034: Part 5, and DIN VDE 0530: Part 5. IP numbers (such as IP34, IP42, IP55) indicate the degree of ingress protection of the product, with the first digit indicating protection against the ingress of objects, and the second digit indicating the degree of protection against the ingress of water.

EN60204-1 is the European Norm covering "The Safety of Machines - Electrical Equipment of Machines".

EN61010-1 is the European Norm covering "Safety requirements for electrical equipment for measurement, control and laboratory use".

EN50081-1 is the European Norm covering "Electromagnetic compatibility - Generic Emission standard - Residential, commercial and light industry".

EN50082 - 1 is the European Norm covering "Electromagnetic compatibility - Generic Immunity standard - Residential, commercial and light industry".

Spare parts availability

Watson-Marlow's policy is to provide spare parts for all products for a minimum of eight years from discontinuation. For major products, this period is extended to twelve years. The ability to implement this policy is not entirely within Watson-Marlow's control and cannot be guaranteed, but every effort will be made to honour this policy.

Common conversions

To go from	Multiply by	To get to
bar	14.50377	psi
inches	25.4	mm
deg C	$(1.8 \times C) + 32$	deg F
gal (IMP)	4.5460	litres
gal (US)	3.7854	litres
gal (IMP)	1.20095	gal (US)
gpm (US)	0.22712	m ³ /hr
gpm (IMP)	0.27276	m ³ /hr
inches Hg	1.1329	ft H ₂ O
inches Hg	0.4912	psi
kg/cm ²	14.22334	psi
kW	1.341	hp
kPa	0.14504	psi
N/m ²	1.0	Pa
Pa	0.00001	bar
litre	0.0001	m ³
kgcm	0.098	Nm

825

25mm High-flow, hygienic pump

825

Provides 2000 litre/hr
(0.33 litre/rev)

Twin stainless steel rollers

Hinged door with only two captive bolts makes changing tube extremely simple and safe

Use USP Class VI Bioprene tubing for 2 bar (29 psi) and 3.5 bar (51 psi) operation

Tube elements complete with hygienic connectors

Tubing in extended element lengths for fitting customers own connectors

Bareshaft pumpheads to take a range of foot-mounted motors with flexible couplings

Pumpheads to accept IEC B5 output flange-mounted gear motors



Standards

BS800, IEC 335-1,
EN60529 (IP55) CE

825R or B/R Motor power/tube life

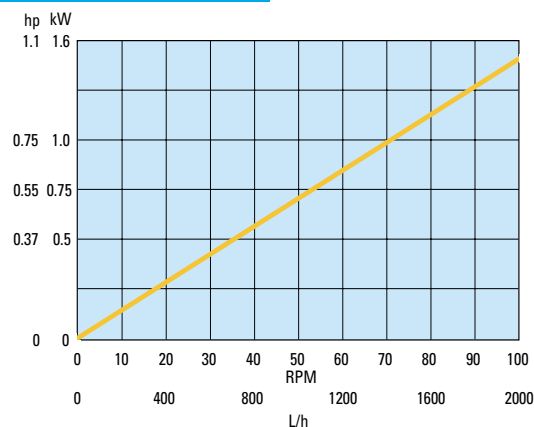

Ordering information

Pumps

825B/R	Baseplate mounted bareshaft pumphead	080.2500.000
825RA	Pumphead with bareshaft adaptor (no baseplate)	083.2510.000

Bioprene tubing for 825 pumps

Tube bore				
25mm	1"	2 bar TM tube element	770mm length	088.0250.E0M
25mm	1"	3.5 bar TH tube element	770mm length	088.0250.E0H
25mm	1"	2 bar TM tube element	2.3m length	088.0250.00M
25mm	1"	3.5 bar TH tube element	2.3m length	088.0250.00H

Connectors for 825 pumps

825CT	Triclamp hygienic connector	1"	089.0250.00T
825CS	SMS hygienic connector		089.0250.00S
825CI	IDF/ISS hygienic connector		089.0250.00R
825CQ	Quick coupling (MIL-C-2748F)	1"	089.0250.00Q
825CR	Quick RJT (BS1864) connector		089.0250.00R

Tube lubricant

400g	Translucent food machinery grease (USDA-H1) approved	098.0005.000
------	--	------------------------------

WATSON MARLOW

Drive options

A number of motor/gearbox options and control options are available for these pumps including fixed and variable speed with mechanical variations. The options include inverter control enabling 4-20mA and 0-10V process control, remote stop/start and reverse, and frequency output.

Configurations

All 800 series pumps are available from Watson-Marlow as complete, ready to run, motorised pumps with a two year warranty.

Each pump supplied by Watson-Marlow is a fully assembled, ready-to-run unit, or a B/RA or an RA bare shaft, ready-to-drive pumphead, which complies with all relevant EU (European Union) safety directives and carries the relevant CE mark or declaration of incorporation.

Fixed speed pumps

825 and 840 pumps can be supplied as a complete speed units fitted with an IP55 motor and gearbox in 4 different speeds.

825FB/R pump speeds are 22, 38, 68 and 98 rpm. 840FB/R pump speeds are 22, 39, 62 and 100 rpm.

Variable speed inverter controlled pumps

We supply complete electronically variable speed pumps with two maximum speeds with a 5:1 reduction ratio. The minimum flow rate will be approximately 20% of the maximum achievable.

Watson-Marlow have selected as standard accessories, single phase input/three phase output inverters for use with the 800 series pumps (maximum power requirement 1.5KW, for use with the 825 pumps and 2.2KW for use with 840 pumps).

All Watson-Marlow pumps are available fitted with motorised geared units to suit the users own choice of inverter.

Mechanically variable speed pumps

All Zone 1 Exd 800 series pumps and those rated above 2.2KW are fitted with belt driven mechanically variable speed gearboxes and IP55 standard motors.

Explosion-proof pumps

All pumps are available fitted with Exd IIB T4 specification explosion-proof motors that meet all EU explosion-proof standards. Specially selected combinations of explosion-proof motors and electronic inverters are available. These inverters are not fitted with explosion-proof casework and therefore must be sited outside the hazardous area.

Accessories

Pulsation dampers will be required for certain applications. Watson-Marlow will supply pulsation dampers from the Flowguard range.









Tube failure detectors are available to order.

A choice of feet or castors for fitting to 825 and 840 pump frames are available.

840

40mm High-flow, hygienic pump

840

-  Provides 8000 litre/h (1.33 litre/rev)
-  Twin stainless steel rollers
-  Hinged door with two captive bolts makes changing tube extremely simple and safe
-  Use USP Class VI Bioprene tubing for 2 bar (29 psi) and 3.5 bar (51 psi) operation
-  Tube elements complete with hygienic connectors or
-  Tubing in extended element lengths for fitting customers own connectors
-  Bareshaft pumpheads to take a range of foot-mounted motors with flexible couplings
-  Pumpheads to accept IEC B5 output flange-mounted gear motors



Standards

BS800, IEC 335-1,
EN60529 (IP55) CE

840R or B/R Motor power/tube life

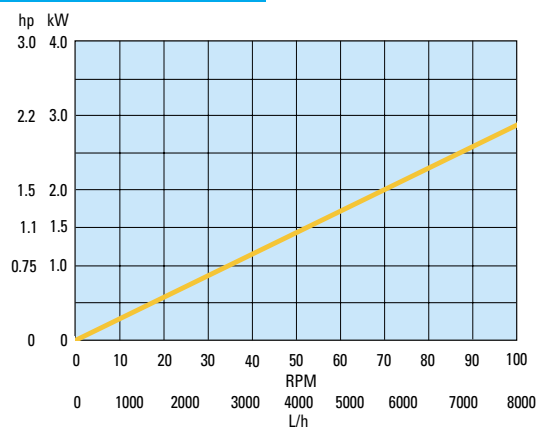

Ordering information

Pumps

840B/RA	Baseplate mounted bareshaft pumphead	080.4000.000
840RA	Pumphead with bareshaft adaptor (no baseplate)	083.4010.000

Bioprene tubing for 840 pumps

Tube bore			
40mm	1 $\frac{3}{8}$ "	2 bar TM tube element	1.25m length 088.0400.E0M
40mm	1 $\frac{3}{8}$ "	3.5 bar TH tube element	1.25m length 088.0400.E0H
40mm	1 $\frac{3}{8}$ "	2 bar TM tube element	2.5m length 088.0400.00M
40mm	1 $\frac{3}{8}$ "	3.5 bar TH tube element	2.5m length 088.0400.00H

Connectors for 840 pumps

840CT	Triclamp hygienic connector	2"	089.0400.00T
840CS	SMS hygienic connector		089.0400.00S
840CI	IDF/ISS hygienic connector	2"	089.0400.00R
840CQ	Quick coupling (MIL-C-2748F)		089.0400.00Q
840CR	Quick RJT (BS1864) connector		089.0400.00R

Tube lubricant

400g	Translucent food machinery grease (USDA-H1) approved	098.0005.000
------	--	------------------------------

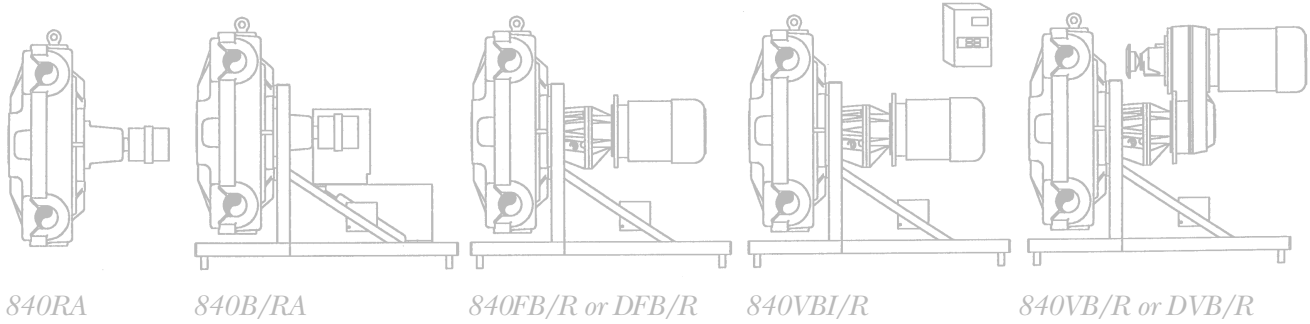

Dimensions mm

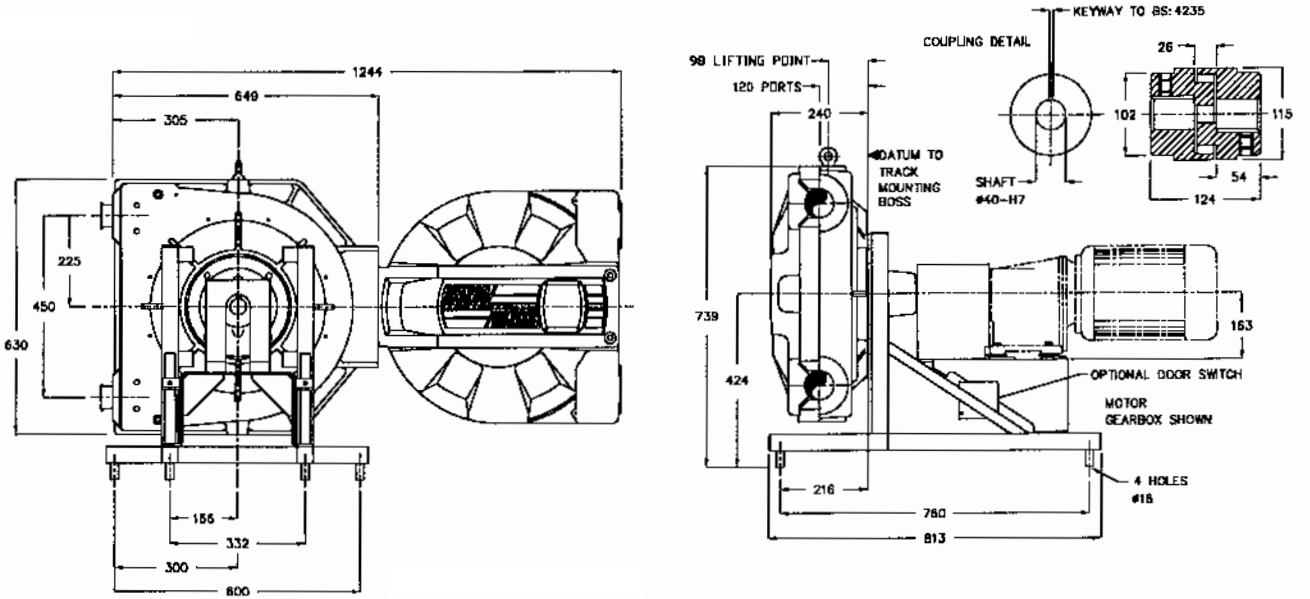

840B/RA

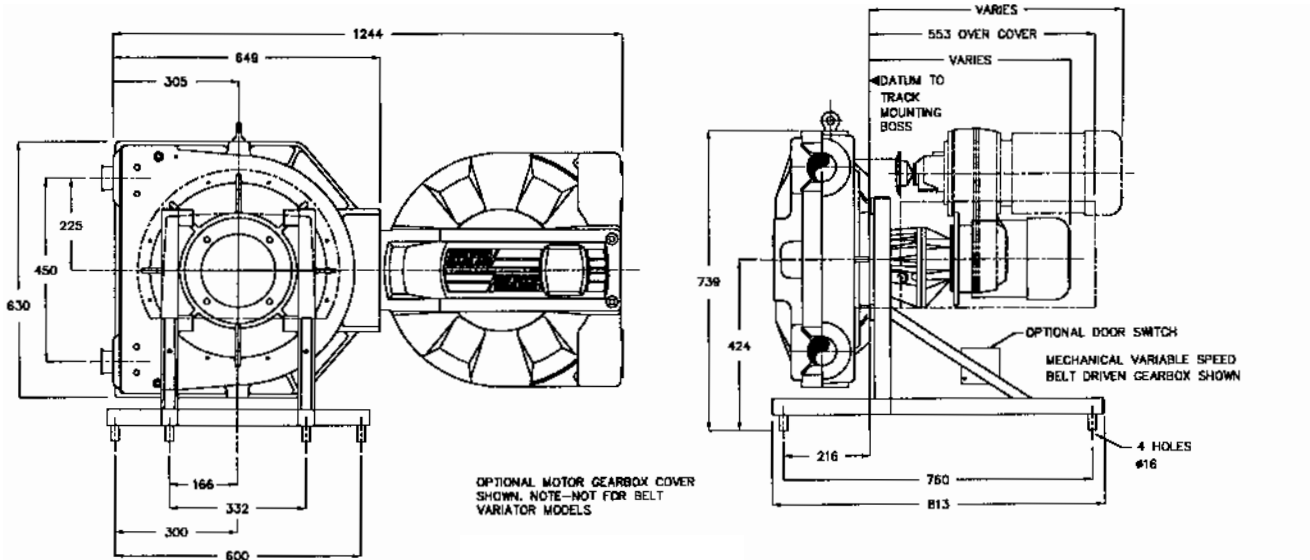

840FB/R, 840VBI/R, 840DFB/R, 840DVB/R



800

Connectors

800 series pumps may be used with either tube elements fitted with hygienic connectors or extended element lengths. A choice of connector types is offered, including Triclamp (Triclover and 3A compatible), IDF and SMS sanitary, and RJT. These are constructed from 316 stainless steel and are totally autoclavable.



Operating and storage temperatures

Unless otherwise stated, all pumps listed in this brochure may be operated at ambient temperatures between 5C and 40C (41F and 104F). They may be stored at temperatures between -40C and 70C (-40F and 158F), but allow time for acclimatisation before operating.

Flow rates

All flow rates quoted in this brochure were obtained pumping water at 20C (68F) with zero suction and delivery heads.

Tube life

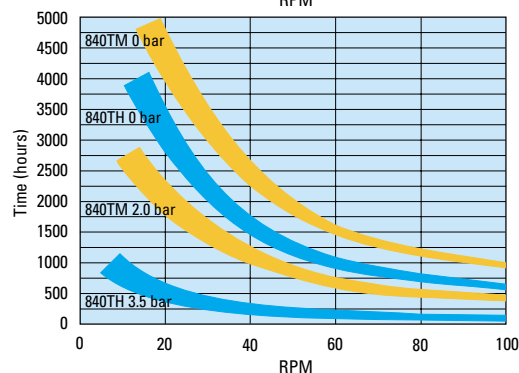
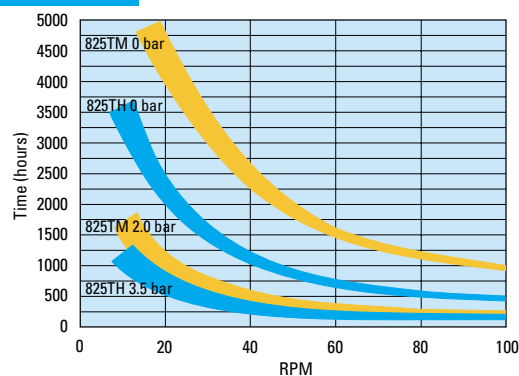

Tubing

The Watson-Marlow 800 series pumps use a Bioprene tube which meets USP and NFS Class VI requirements. Bioprene also complies with FDA 21 CFR 177.260 and meets USDA standards for food handling.

High pressure applications

For specific higher pressure applications, use 3.5 bar "TH" tubing elements for intermittent periods only. Do not use quick connectors for this process. Tubing previously used as a pumping element should not be used as a transfer section.

Tube lubricant

Translucent food machinery grease (USDA-H1 approved for food contact) is available for 800 series tubing to prolong tube life.

High pressure tube life

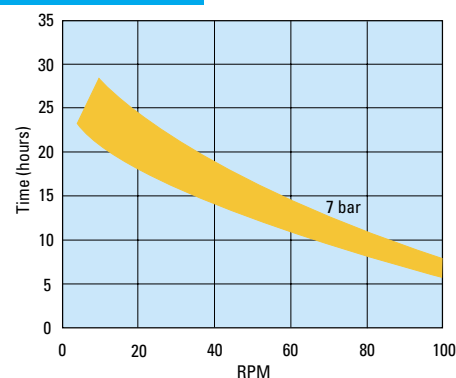

800

Materials of construction

Description	Material
Pumphead body	Aluminium alloy with epoxy polyester powder coat finish
Pumphead door	Aluminium alloy with epoxy polyester powder coat finish
Pumphead rotor	Aluminium alloy
Rotor rollers	316 stainless steel
Frame	Stainless steel 304L
Optional motor housing	Stainless-steel 304L
Door fixings	Stainless steel
Motor fixings	Zinc plated high tensile steel bolts, stainless steel nuts and washers
Frame fixings	Stainless steel

Paint specification

The 800 series epoxy polyester powder coating is based on a mixed polymer thermosetting resin designed to combine the durability associated with epoxies with the enhanced UV and heat stability associated with polyesters. This results in a high quality finish which is abrasive and impact resistant.

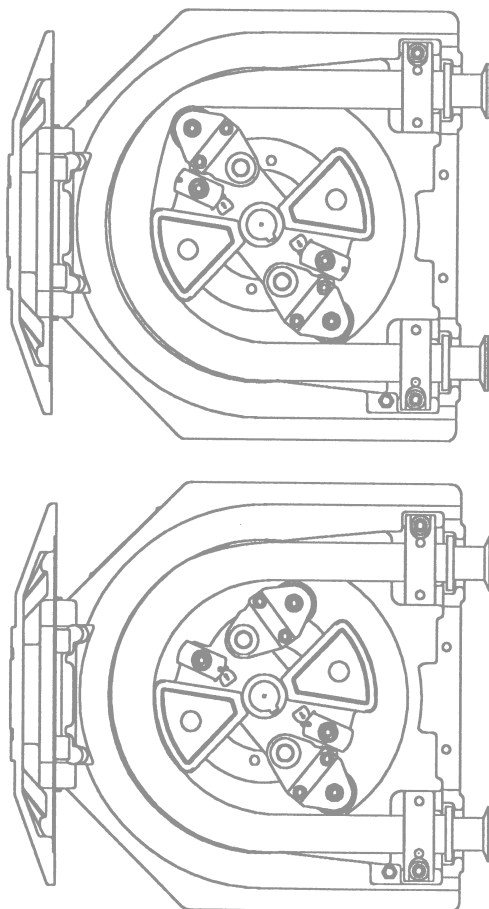

Installation drawings

Installation drawings of all 800 series pumps are available on request in A3 size. Reproducible drawings are also available for a modest fee.

Custom-built pumps

Watson-Marlow Limited's team of technical support engineers is available to advise and quote for your custom-built pumps with electric, hydraulic or pneumatic motors, trolley mounting, stainless steel baseplates etc.

CIP

The 800 series pumphead incorporates retractable roller mechanisms which allow clean-in-place or steam-in-place hose cleaning. The roller mechanisms are simply unlocked and disengaged from the standard pumping position, providing maximum cleaning capacity via a free flow of cleaning agents through the hose.

SIP

The 800 series can be steamed-in-place at 135°C (2 bar) for a duration of one hour. Allow 15 minutes for pump to return to ambient temperature prior to restarting pump.

Flow rates

Up to 8,000 litres/hour depending upon motor speed.

Pressures

Up to 3.5 bar continuous operation governed by motor sizing.

Drive options

Fixed speed, variable speed (inverter or mechanical variator), all drives available with Exd options. Contact Watson-Marlow Technical Support for further information.

Duty rating

24 hour governed by motor sizing.

825

25mm hygienic pumps



840

40mm hygienic pumps



The 800 series pumps have been designed for hygienic pumping up to 8000 litre/hour and pressures to 3.5 bar (51 psi), in the biotechnology, pharmaceutical and food industries. Pumpheads are constructed of aluminium with an epoxy powder coated white finish and they offer true CIP (clean-in-place) and SIP (steam-in-place) as the rollers retract to a non-occluding position, allowing a complete flow-through for cleaning.

All pumps are mounted on a stainless steel frame with the option of a brushed stainless steel motor housing, where belt variators are not required.

Watson-Marlow's focus has been to minimise the total cost of ownership over the lifetime of the pumps by making them reliable, long-lasting, and simple to use and maintain. Downtime is the true enemy of productivity, and so minimising downtime and whatever essential maintenance is required rewards our care and your choice of pump.

For instance and (uniquely), access to the tube is through a hinged door rather than a lift-off cover, and the door is secured by two captive bolts rather than sixteen or twenty loose ones, making tube changing fast, simple and safe.

Bioprene tube elements with hygienic connectors are autoclavable and can be fitted quickly and cleanly.

Where hygiene and system up-time is valued, there is no better pump than a Watson-Marlow 800 series.

**WATSON
MARLOW****Unmatched warranties**

The high quality of the design and manufacture of Watson-Marlow products allows us to offer international warranties far exceeding those available for other pump types.

All 800 series pumps carry a two year warranty.



WATSON MARLOW PUMPS

The information contained in this document is believed to be correct but Watson-Marlow Limited accepts no liability for any errors it contains, and reserves the right to alter specifications without notice.

Watson-Marlow Limited



Belgium
Telephone 02 529 5858
Fax 02 529 5861
Web www.watson-marlow.com/watson-marlow/
Email bs.support@watson-marlow.com

France
Telephone (1) 30 62 12 47
Fax (1) 30 66 11 22
Web www.watson-marlow.com/watson-marlow/
Email fs.support@watson-marlow.com

Germany
Telephone 02183 42040
Fax 02183 82592
Web www.watson-marlow.com/watson-marlow/
Email ds.support@watson-marlow.com

Italy
Telephone (03) 0687 1184
Fax (03) 0687 1352

Korea
Telephone 02 525 5755
Telex K26177
Fax 02 525 5764
Web www.watson-marlow.com/watson-marlow/
Email k.support@watson-marlow.com

The Netherlands
Telephone 010 462 1688
Fax 010 462 3486
Web www.watson-marlow.com/watson-marlow/
Email nl.support@watson-marlow.com

Singapore
Telephone (65) 456 7274
Fax (65) 457 5912

United Kingdom
Telephone +44 1326 370370
Fax +44 1326 376009
www.watson-marlow.com/watson-marlow/
Email support@watson-marlow.co.uk

United States of America
Telephone 800 282 8823
Fax 508 658 0041
Web www.watson-marlow.com/watson-marlow/
Email us.support@watson-marlow.com



S E R I E S

100/200

Low-flow pumps

100 series flow rates from 0.01 to 53 ml/min. Single channel. Fixed and variable flow rates.



Multi-channel pumps

200 series flow rates from microlitres to 32 ml/min. through up to 32 channels. Manual and auto-control.

● HB 0065



300

Low-cost pumps

Flow rates from 0.2 to 2,000 ml/min. Fixed and variable speeds.

● HB 0060



500

Microprocessor controlled pumps

Flow rates from 0.01 to 2,200 ml/min. 1 to 48 channels. Manual, auto and digital control.

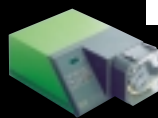

IP55 rated pumps

Washdown pumps for tough environments, and pneumatic or baseplate-mounted pumps with Exd motors for hazardous areas. Flow rates to 2.2litre/min.

● HB 0062

600

Mid flow pumps

Cased pumps or baseplate-mounted pumps for flows up to 15.8 litre/min (4.2 US gpm). Fixed or variable speed and single channel.

● HB 0063



700

High-flow pumps

IP55 rated pumps with manual or auto control and baseplate-mounted industrial pumps provide flows to 2,000 litre/hr (8.8 US gpm). Single or twin channel.

● HB 0060



800

High-flow hygienic pumps

Use Bioprene USP Class VI tubing for flow rates up to 8,000 litre/hr (35 US gpm), and pressures up to 3.5 bar (50 psi). True CIP and SIP facilities ideal for biotech, pharmaceutical and food industries. Single channel.

● HB 0057



900

High-flow, high-pressure pumps

Use reinforced tubing in five different materials for flow rates up to 10,000 litre/hr and pressures up to 15 bar (210 psi). Single channel.

● HB 0056



Dispensers & Robotic fillers

For repetitive and accurate dosing and dispensing duties. Straightforward stop/start volumes up to one litre in five seconds or precision, balance-controlled dispensing.

● HB 0039



OEM pumps

Pumpheads for use with customers' own drives or plate-mounted pumpheads and motors. Compact, easy to install and to use. Single and multi-channel with flow rates up to 2,700 ml/min.

● HB 0076



Tubing

Twelve different materials and over 50 sizes of tubing for the complete range of Watson-Marlow pumps. Full chemical compatibility tables with 450 fluids tabulated. Performance and physical data.

● HB 0065



Members of the Spirax-Sarco Engineering Group

Watson-Marlow is a registered trademark of Watson-Marlow Limited.

Publication ref. HB 0057

● These brochures describe the full Watson-Marlow range of peristaltic pumps, tubing and accessories.

ST DESIGN